



400 Series

403D-15

Industrial Open Power Unit

24.2 kW/32.5 bhp



The Perkins 400D range has been developed in consultation with our market-place. This 1.5 litre, 3 cylinder engine complete with radiator cooled unit, compliments the exciting 400 Series product line-up, offering customers a choice of ultra-compact, lightweight power units whilst maintaining all the customer benefits they can experience from other products in the range.

Ultra-compact power

- Up to 24.2 kW from an engine envelope of 0.32m³
- Easy installation

Clean and quiet

- Noise levels have been kept to a minimum
- Subjective harshness has also been controlled, making the engine sound even quieter

Durable and reliable

- Product design and process improvements enhance both engine reliability and durability
- A new improved (advanced) governor, valve seat inserts, and new compliance testing deliver reliability of 6,000 hours
- A standard 2 year warranty demonstrates our confidence in durability and reliability of our engines

Low operating costs

- Approved for operation on biodiesel* concentrations of up to 20%
- Oil and filter changes are 500 hours, dependent on load factor
- Engine durability and reliability, the warranty offering, and ease of installation combine to drive down the cost of ownership

Product support

- Perkins actively pursues product support excellence by ensuring our distribution network invest in their territory - strengthening relationships and providing more value to you, our customer
- Through an experienced global network of distributors and dealers, fully trained engine experts deliver total service support around the clock, 365 days a year. They have a comprehensive suite of web based tools at their fingertips covering technical information, parts identification and ordering systems, all dedicated to maximising the productivity of your engine
- Throughout the entire life of a Perkins engine, we provide access to genuine OE specification parts and service. We give 100% reassurance that you receive the very best in terms of quality for lowest possible cost .. wherever your Perkins powered machine is operating in the world

The 400 Series engine family continues to set new standards in the compact engine market. Developed alongside customers to fulfil their needs in the construction, materials handling, agricultural/turf, genset and compressor markets, it is another class-leading diesel range from Perkins.

Built to the most demanding standards, the 400D engines meet all the requirements of the off-highway EU and EPA emissions legislation (see 'Perkins Emissions Statement' on page 2).

Perkins IOPUs offer the advantages of an industrial engine, with the convenience of a cost effective cooling and filtration solution. This minimises machine development time and costs, and enables applications to be powered with ease.

The 403D-15 IOPU is a powerful but quiet 1.5 litre packaged unit. It delivers impressive performance with low operating costs in a small, efficient package ideal for a range of industrial applications.

Performance Data	Maximum Power			Maximum Torque		
	Speed rpm	kW	bhp	Nm	lbf.ft	Speed rpm
Net Intermittent	3000	24.2	32.5	94.4	69.6	1800
Net Continuous	3000	21.1	28.3	82.1	60.6	1800
Net Intermittent	2800	23.9	32.1	94.4	69.6	1800
Net Continuous	2800	20.8	27.9	82.1	60.6	1800

*Subject to conformance with ASTM D6751 and EN14214.

Photographs are for illustrative purposes only and may not reflect final specification.

All information in this document is substantially correct at time of printing and may be altered subsequently

Publication No. 1900/01/10 Produced in England ©2007 Perkins Engines Company Limited

400 Series

403D-15

Engine Specification

- Cast iron engine block
- SAE Flywheel size 7½
- SAE 4 flywheel housing
- Fuel injection pump
- Fuel filter
- Glow plug starting aid
- Lub oil sump
- Spin on lub oil filter
- Inlet manifold
- Cast iron exhaust manifold – side outlet
- Coolant pump belt driven
- Mounted radiator and fan
- Mounted air cleaner
- Starter motor 12 volt
- Alternator 12 volt 65 amp
- ESOS (Electric shut-off solenoid)
- Lub oil pressure switch
- Coolant temperature switch

General Data

Number of cylinders	3 in-line
Bore and stroke	84 x 90 mm
Displacement	1.496 litres
Aspiration	Naturally aspirated
Cycle	4 stroke
Combustion system	Indirect injection
Compression ratio	22.5:1
Rotation	Anti-clockwise viewed on flywheel
Cooling system	Liquid
Total lubrication capacity	6 litres
Total coolant capacity	5.98 litres
Dimensions	Length 820 mm Width 497 mm Height 793 mm
Dry weight	175 kg

Final weight and dimensions will depend on completed specification.

Option Groups

A selection of optional items is available to enable you to prepare a specification precisely matched to your needs.

Emissions Statement

- **Variable Speed:** Industrial and IOPU engines: Certified against the requirements of EU Stage IIIB (Directives 97/68/EC, as last amended, and 2005/26/EC, as last amended); and US EPA Tier 4 Interim (40CFR Parts 1039. (NOTE Tier 4 Final will start in 2013 model year for 19-56 kW engines).

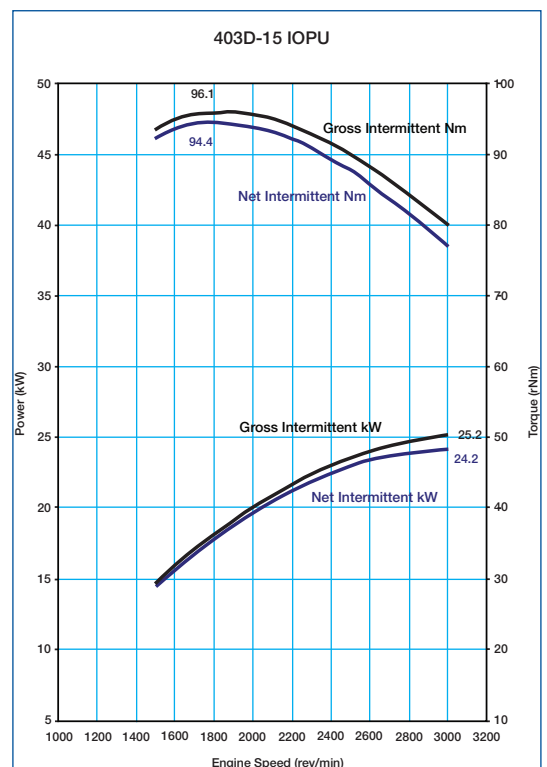
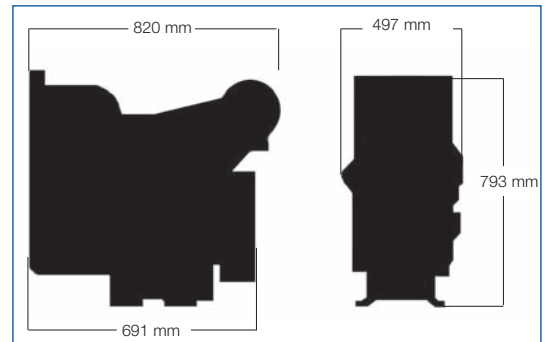

Lower speed ratings cannot be read from this curve.

- **Constant Speed Engines** for use in Industrial, IOPU and ElectropaK applications: Certified against the requirements of EU Stage IIIA (Directives 97/68/EC, as last amended, for mobile applications); and US EPA Tier 4 Interim (40 CFR Parts 60 for stationary applications and 40CFR Part 1039 for mobile applications).



Perkins Engines Company Limited

Peterborough PE1 5NA
United Kingdom
Telephone +44 (0)1733 583000
Fax +44 (0)1733 582240
www.perkins.com

Distributed by