

V O L V O



Volvo Articulated Hauler 25.0 t 53 km/h 320 hp

A25

Volvo Construction Equipment

A25

Built to deliver optimum productivity, profitability and performance – the Volvo A25 Articulated Hauler is a leader in its class and the optimum choice for general construction, heavy infrastructure and quarrying.



Intuitive in-cab interface

- All essential in-cab information conveniently displayed on just two screens
- Interactive, integrated Volvo Co-Pilot display
- Dynamic instrument cluster in-front of steering wheel



Productive performance

- Outstanding tipping stability
- Width under 3-meters (including tailgate) for easy and convenient transport

Top of the class

A leader in its class, the Volvo A25 Articulated Hauler is built to deliver exceptional off-road performance, outstanding levels of operator comfort and maximum uptime.

With key features including Volvo drivetrain with Terrain Memory, an intuitive operator interface, visibility which exceeds industry standards, superior durability and lower maintenance costs, get ready to take on the most challenging projects across general construction, heavy infrastructure, quarrying and more.

Unbeatable off-road performance



- Proven Volvo drivetrain
- Automatic traction control (ATC), including Terrain Memory*
- Automatic drive combinations (including 100% differential locks)
- All-terrain bogie and hydro-mechanical steering
- Volvo Dynamic Drive

Total operator control



- Hill assist
- Cruise control
- Downhill speed control
- Load and dump brake
- Dump support system
- Dynamic Volvo Engine Brake

Enhanced visibility



- Redesigned hood and cab panels
- Wider wiper coverage
- Direct field of vision which exceeds industry standards
- Optional work lights located on the pillars
- Optional front and rear cameras; standard entrance camera
- Camera views easily managed using Volvo Co-Pilot

Designed for uptime



- 250-hour greasing intervals
- 1 000-hour engine service intervals
- Industry leading service access
- Robust access
- Remote monitoring and service alerts
- Enhanced electrical service center
- Service contracts
- Enhanced fuel filter water separator system
- Harness anchor points

Ultimate operator experience



- Easy access/egress
- Ergonomic gear lever
- Enhanced storage options
- Easy cleaning
- Durable gas-hydraulic suspension
- Operator Training Program

Smarter Solutions



- Haul Assist with On-Board Weighing
- Connected Map and Performance Indicator
- Future proofed software architecture
- CareTrack
- My Equipment app
- Site optimization consultancy service

* In markets with CareTrack

Unbeatable off-road performance

The Volvo Articulated Hauler delivers best-in-class off-road performance with features including the proven Volvo drivetrain, automatic drive combinations (including 100% differential locks), all-terrain bogie and hydro-mechanical steering for unmatched traction, stability and precision control. With Volvo Dynamic Drive, dynamic and predictive gear selection adapts to the operating conditions at hand, for improved comfort and fuel efficiency.

Intuitive operator interface

Operators can stay in-the-know and focussed on the task at hand thanks to all essential in-cab information conveniently displayed on two screens. The interactive, integrated Volvo Co-Pilot display offers easy control over essential functions such as media, camera settings, climate control, and machine status. This is combined with the dynamic instrument cluster, positioned in front of the steering wheel, which provides essential vehicle data at a glance.

Haul Assist with On-Board Weighing

Haul Assist, powered by the integrated Volvo Co-Pilot, is a set of tools designed to help you get even more productivity and efficiency from your Volvo Articulated Hauler. A key feature of Haul Assist is On-Board Weighing, which provides real-time payload information which can help to eliminate carry-back and overloading. The result is peak productivity, reduced fuel consumption and less machine wear.

Volvo DNA throughout the powertrain

Experience superb fuel efficiency without compromising on power and performance thanks to the world-renowned Volvo drivetrain, complete with automatic traction control (ATC), including Terrain Memory*. The intelligent function identifies and remembers slippery road segments to ensure optimized traction control and outstanding off-road mobility.

* In markets with CareTrack



Total operator control

Features including hill assist, cruise control, downhill speed control, load and dump brake and dynamic Volvo Engine Brake help operators achieve optimum results all day, every day.

Lower maintenance costs

Keep service costs to a minimum thanks to simplified servicing, longer change intervals and easy component access. Servicing your machine is quick and easy thanks to industry leading service access and essential maintenance points accessible from the ground. What's more, eliminate daily or weekly greasing thanks to industry leading greasing intervals of 250 hours for maximum uptime.



Volvo A25 in detail

Engine

11 liter, 6-cylinder in line turbocharged (fixed geometry) diesel engine with 4 valves per cylinder, overhead camshaft and electronically controlled unit injectors. The engine has wet replaceable cylinder liners and replaceable valve guides and valve seats.

Engine Model	D11F	
Max power - SAE J1995 Gross	kW	235
	hp	320
at engine speed	rpm	2 100
Flywheel power - ISO 9249, SAE J1349 Net	kW	234
	hp	318
at engine speed	rpm	2 100
Max torque - SAE J1995 Gross	Nm	2 040
Max torque - ISO 9249, SAE J1349 Net	Nm	2 030
at engine speed	rpm	1 100
Displacement	lit	10.8

Electrical System

All cables, sockets and pins are identified. Cables are enclosed in plastic conduits and secured to main frame. Halogen lights. Rewired for options. Connectors meet IP67 standard for water-proofing as necessary.

Voltage	V	24
Battery	V	2 x 12
Battery capacity	Ah	2 x 170
Alternator	kW/A	3.396 / 120
Starter motor	kW	9

Drivetrain

Torque converter with built-in lock-up function.

Transmission: Fully automatic Volvo PowerTronic planetary transmission with six forward gears and two reverse gears. The transmission has the ability to skip gears for fast and accurate gear selection.

Dropbox: Volvo-developed, in-line design with high ground clearance and 100% longitudinal "dog clutch" type differential lock.

Axles: Heavy duty, purpose built Volvo design with fully floating axle shafts, planetary type hub reductions and 100% dog clutch type diff-lock. Automatic traction control system (ATC).

Torque converter	2.37:1	
Transmission	Volvo	PT 2116
Dropbox	Volvo	IL1 ATC
Axles	Volvo	AHW56

Brake System

Fully hydraulic, wet multiple disc brakes with enclosed, forced oil-cooled multiple discs on all wheels. Two circuit brake system. Complies with ISO 3450 at total machine weight.

Circuit division: One circuit for front axle and one for bogie axles.

Parking brake: Spring-applied disc brake acting on the trailer unit propeller shaft. When the parking brake is applied, the longitudinal differential locked.

Retarder: Service brake retarder function and Volvo Engine Brake (VEB).

Steering System

Hydro-mechanical articulated steering, self compensating design. Two double-acting steering cylinders.

Steering angle: 3,4 steering wheel turns lock-to-lock, $\pm 45^\circ$.

Steering system, including secondary steering fulfills ISO 5010.

Chassis

Frames: box type, heavy duty. High strength steel, robot welded.

Rotating hitch: 100% maintenance free, fully sealed, with permanently greased tapered roller bearings.

Cab

The Volvo cab features excellent all-around visibility created by a centrally positioned operator station, sloping hood, large rear-view mirrors and entrance camera. The one piece wide front windshield with large swipe area further enhances visibility.

The central instrument cluster, the integrated Co-pilot, gearshift lever, tipping lever and easy to reach switches ensure ease of operation.

The spacious cab meets the ROPS/FOPS safety standards according to ISO3471, SAE J1040 / ISO3449, SAE J231. Controls are ergonomically designed and easy to understand. Large storage compartments and a cooled/heated box improves the operator comfort.

Sound level in cab (ISO 6396) - L _{PA}	dB	72
External sound level (ISO 6395) - L _{WA}	dB	110
Internal sound level with sound kit	dB	70
External sound level with sound kit	dB	108



Hydraulic System

Pumps: Four variable displacement piston pumps driven by the flywheel PTO.

Two load-sensing used for steering and tipping and two electrical controlled used for fan, brake cooling and brake power supply. One ground-dependent piston pump for secondary steering mounted on the dropbox.

One return oil filters with magnetic cores provide effective oil filtration.

System max working pressure	MPa	25
-----------------------------	-----	----

Dumping System

Patented Load and Dump Brake.

Dumping Cylinders: two single stage double acting cylinders.

Tipping angle	°	74
---------------	---	----

Tipping time with load	s	12
------------------------	---	----

Lowering time	s	10
---------------	---	----

Body

Plate thickness

Front	mm	6
-------	----	---

Sides	mm	10
-------	----	----

Bottom	mm	14
--------	----	----

Chute	mm	14
-------	----	----

Material HB450 steel

Yield strength	N/mm ²	1 150
----------------	-------------------	-------

Tensile strength	N/mm ²	1 350
------------------	-------------------	-------

Load Capacity

Standard body

Load capacity	kg	25 000
---------------	----	--------

Body, struck	m ³	12.1
--------------	----------------	------

Body, heaped 2:1	m ³	15.3
------------------	----------------	------

With overhung tailgate

Body, struck	m ³	12.4
--------------	----------------	------

Body, heaped 2:1	m ³	15.9
------------------	----------------	------

Suspension

Front suspension: Gas-hydraulic struts. Soft and progressive. Independent wheel movement via a 3-point mounting system.

Rear suspension: 100% maintenance free. Straddle mounted bogie beam. Independent wheel movement via a 3-point mounting system.



Specifications

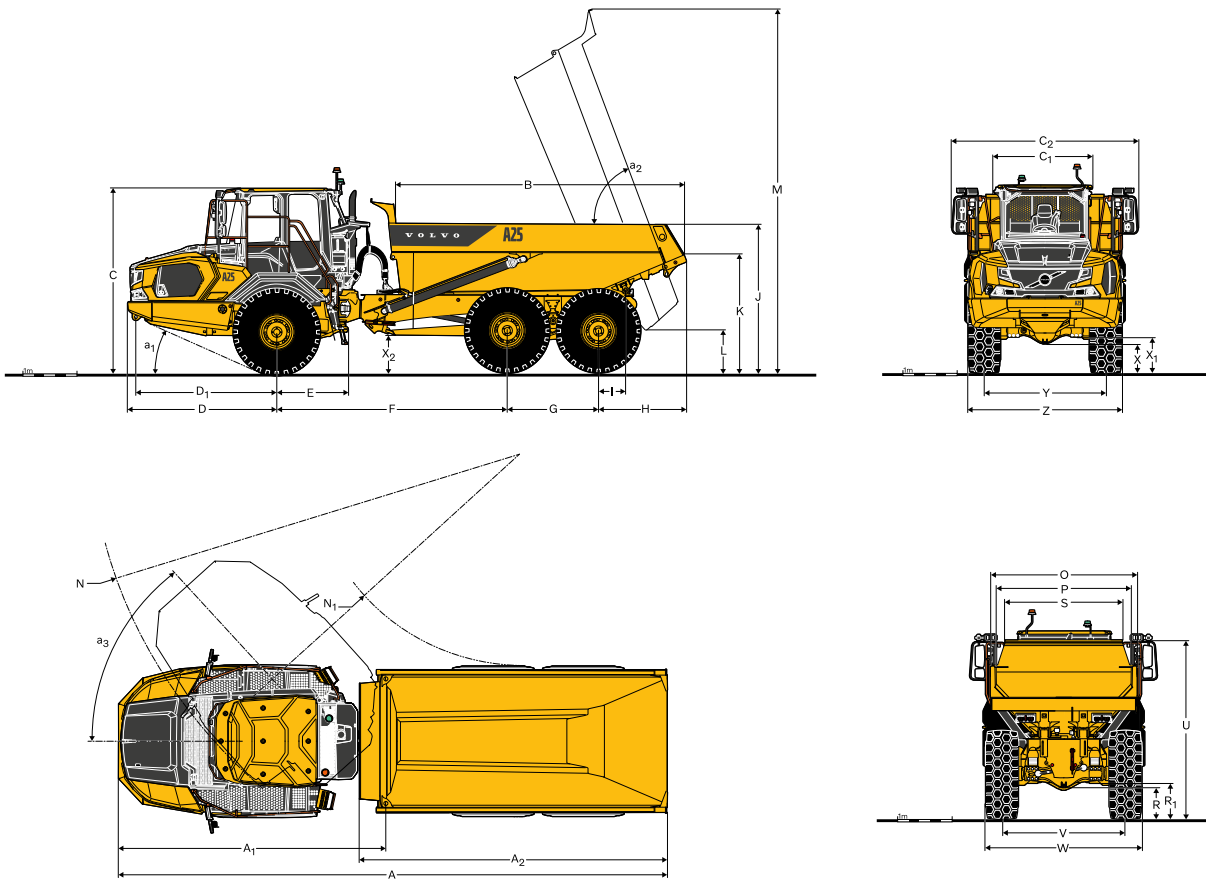

DIMENSIONS		
Pos	Unit	A25J
A	mm	10 344
A*	mm	10 436
A ₁	mm	4 953
A ₂	mm	5 832
B	mm	5 362
C	mm	3 404
C ₁	mm	1 819
C ₂	mm	3 457
D	mm	2 762
D ₁	mm	2 607
E	mm	1 210
F	mm	4 264
G	mm	1 690
H	mm	1 628
I	mm	501
J	mm	2 748
K	mm	2 187
L	mm	620
M	mm	6 518
N	mm	8 175

DIMENSIONS		
Pos	Unit	A25J
N ₁	mm	4 190
O	mm	2 670
O*	mm	2 838
P	mm	2 464
R	mm	529
R ₁	mm	650
S	mm	2 175
U	mm	3 229
V	mm	2 258
W	mm	2 871
X	mm	472
X ₁	mm	599
X ₂	mm	687
Y	mm	2 258
Z	mm	2 871
a ₁	°	24
a ₂	°	72
a ₃	°	45

A25J: Unloaded machine with 23.5 R25

*Dimension with overhung tailgate

REFILL CAPACITIES		
		A25J
Crankcase	l	35
Fuel tank	l	380
Cooling system	l	-
Brake cooling system	l	42
Transmission	l	48
Dropbox	l	9.0
Axles, front/bogie	l	24 / 50
Hydraulic tank	l	170

SPEED		
		A25J
Forward		
1	km/h	8.3
2	km/h	11.9
3	km/h	21.1
4	km/h	30.3
5	km/h	38.4
6	km/h	52.7
Reverse		
1	km/h	7.7
2	km/h	13.7

OPERATING WEIGHT UNLOADED		
		A25J
Tires		23.5R25*
Front	kg	12 700
Rear	kg	10 200
Total	kg	22 900
Payload	kg	25 000

TOTAL WEIGHT		
		A25J
Tires		23.5R25*
Front	kg	14 700
Rear	kg	33 200
Total	kg	47 900

Operating weight includes all fluids and operator

*) A25J with tires 750/65R25, add 200 kg / axle

*) A25J with tires 750/65R25, add 200 kg / axle

GROUND PRESSURE			
		A25J	
Tires		23.5R25	750/65R25
Unloaded			
Front	kPa	130	110
Rear	kPa	50	44
Loaded			
Front	kPa	130	128
Rear	kPa	50	140

Equipment

STANDARD EQUIPMENT

Cab/Operator environment

Operator seat with head restraint (air suspended and heated)

Electronic Climate Control

Cup holder / storage tray

Cell phone holder

Instructor seat with seat belt

Overhead console for CC Radio, Tachograph, etc.

Air suspended / heated operator seat

Sliding window

Cooled / Heated storage box

Front sun visor

Tilt/telescopic steering wheel

Loud speakers (4)

Dynamic instrument cluster and integrated Co-Pilot

Automatic pre-start checks

Troubleshooting diagnostics

Engine

Preheater for easier cold starts

VEB (exhaust retarder EPG + compression brake)

Wheels and tires

26.5R25

Drivetrain

6x4 and 6x6 Automatic Traction Control (ATC)

Dog clutch type 100% diff-locks in all axles

Cruise Control

Dropbox with longitudinal diff-lock

Torque converter with automatic lock-up in all gears

Electrical system

Battery disconnect switch

Electrical Interface

Charging studs

Power outlets

USB-C 2.0 (2)

USB-A 3.0 (1)

24V (2)

Exterior and Interior lights (all LED)

Brake system

Two circuit, fully hydraulic, wet discs on all axles (externally cooled)

Down Hill Speed Control

Hill assist

Load & Dump Brake

Retarder pedal

Parking brake on propeller shaft

STANDARD EQUIPMENT

Dumping System

Body prepared for exhaust heating and optional equipment

Safety and security

Anti-slip steps and platforms with handrails

Dump body lock

Steering joint lock

Harness anchor points

Rear-view mirrors

Retractable 3-inch 2-point safety belt

ROPS / FOPS protected Care Cab

Secondary steering

Dump support system

Positioning indicators (front and rear)

Entrance camera

Service and Maintenance

Grouped service points and filters

Electrical fuel priming pump

Prepared for fast fueling equipment

Ambient and service lights (LED)

Electrical engine hood

Belly plate with integrated service hatches

Drainage hoses

Tool box

Front service ladder

OPTIONAL EQUIPMENT
Engine
Air filter, heavy duty
Engine heater, electric
Engine heater, diesel
Engine shutdown timer
External emergency engine stop
Operator Environment
Noise reduction kit (fulfils 2000/14/EC)
Anchorage, operator's manual
Cab heating / ventilation timer
Cable kit, for cab heater
Cab air filter (Asbestos dust protection)
Cab air filter (Carbon)
Rear view mirrors, adjustable, el.heated
Sun blinds, side windows
Universal key
Premium operator seat with head restraint (air suspended, cooled / heated), 2-point belt
Premium operator seat with head restraint (air suspended, cooled / heated), 3-point belt
Armrest for operator seat
Hands-free microphone
Radio AM / FM / DAB
Wheels and tires
775/65R29
Drivetrain
Long haul kit, dropbox cooling
Speed limiter (25/30 km/h)
Electrical system
Warning beacon, LED
Seatbelt indicator, external
Working lights front and rear, LED
Rear view camera
Front view camera
Reverse alarm
PDS interface, Safemine
Tire Pressure Monitoring System

OPTIONAL EQUIPMENT
Suspension
Rubber front suspension
Hydraulic front suspension
Dumping System
Body exhaust heating
Front spillguard, extra
Side extension, 200 mm
Side extension, light material
Tailgate, overhung, wire-operated
Tailgate, overhung, linkage-operated
Tailgate, underhung
Wear plates, 450 HB
Wear plates heavy duty, 450 HB
Safety and security
Fire suppression system
Warning triangle
First aid kit and fire extinguisher
Fire extinguisher, external
Wheel chocks
Service and maintenance
Auto Lube system
Centralized greasing
Tool kit
Other
Arctic oil kit
Fast fuelling system
Jump start connector, ISO-type

V O L V O